

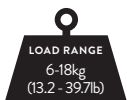

- Accommodates two 24" widescreens with screen rotated between portrait and landscape
- Perfect screen alignment with 12mm of fine height adjustment
- Visual indicator gauge for setting perfect tension and easy replication when installing multiple arms
- Self regulating head design – VESA mount heads counterbalance against screen weight to prevent drooping
- Also available for single screens



info@cbsproducts.co.uk
www.colebrookbossonsaunders.com



colebrook bosson saunders

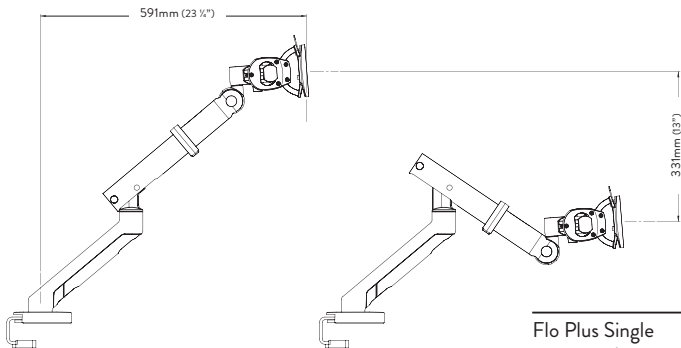

CODE DYN/026

Dynamic Monitor Arm

Flo Plus Single
movement range

587mm (23 1/5") reach
330mm (13") vertical adjustment

TECHNICAL INFORMATION

- Net Product Weight: 6.1kg
- Lifetime Warranty
- VESA 75 and 100 Compliant



	Total Material Weight (g)	Material Type Recycled Content (%)	% PIR of Total Weight	% PCR of Total Weight	% of Total Product Recyclable
Aluminum <small>Die Cast</small>	1877	95	15	13	30
Aluminum <small>Extruded</small>	773	-	-	-	12
Plastic	840	-	-	-	13
Rubber	23	-	-	-	-
Steel	2318	13	1	4	37
Stainless steel	35	60	-	-	1
Zinc	416	44	1	1	7
Brass	5	-	-	-	-
Total	6287	36	17	19	100

Data sheets are available for more detailed product information.
Please contact your Account Manager on +44(0)207 940 4266.